



Purchasing and Distribution Services
702 SE M-291 Highway
Lee's Summit, Missouri 64063
(816) 986-2190
Email: heather.falls@lsr7.net

INVITATION TO BID

DATE: June 15, 2018
FOR: Plastic Laminate Faced Casework
BID#: 2018-43
DATE OF OPENING: July 2, 2018
TIME OF OPENING: 3:00 PM

THE UNDERSIGNED HEREBY:

1. Agrees to deliver the items specified herein in accordance with the terms, conditions specifications and prices set forth.
2. Certifies that he/she is an authorized agent of said company and has the authority to legally enter into a binding contract.

BIDS MUST BE SIGNED IN INK

_____	_____
Name of Vendor	Authorized Representative (Print)
_____	_____
Street Address	Authorized Signature
_____	_____
City	State, Zip Code
_____	_____
Telephone	Contact Email

All questions, requests for information or clarification pertaining to this bid must be submitted in writing to the District's Public Purchase website, www.publicpurchase.com

Note: Vendors may not contact any other staff member of the Lee's Summit R-VII School District or Board of Education during the bid process.

Bidder's Initials _____

**ADVERTISEMENT FOR BIDS:
2018-43 Plastic Laminate Faced Casework**

The Lee's Summit R-VII School District is accepting Bids to deliver Plastic Laminate Faced Casework. The bid document and required specifications can be found on the District's purchasing website. All questions and bids will only be accepted electronically through publicpurchase.com and must be received on or before 03:00 PM (CST) on Monday, July 2nd, 2018. **No Late Bids will be accepted.** Questions regarding Public Purchase registration, contact Purchasing Services (816-986-2190).

SPECIAL INSTRUCTIONS

1. Purpose of Bid: The Lee's Summit R-VII School District is soliciting bids for the purchase of Plastic Laminate Faced Casework (See Equipment Specifications / Pricing page).
2. Bid price shall include new equipment and delivery.
3. All bids shall be quoted **F.O.B. DESTINATION** unless otherwise specified.
4. Delivery Locations: Pleasant Lea Elementary (700 SW Persels Rd, Lee's Summit, MO 64081)
5. Purchase Agreements shall be awarded in accordance with regulations adopted by the Lee's Summit R-VII Board of Education and adhere to all applicable purchasing policies. Purchase Agreements will be negotiated with the lowest responsible bidder who meets the qualifications for quality, price, terms of bid, and service, and determined to be in the best interest of the District. The bid award will be at the sole discretion of the District. The District reserves the right to reject any and all bids in part or in whole, and to accept the bid that is in the best interest of the District.
6. The terms of this bid shall remain in effect for at least one year from date of award. All prices **MUST** remain firm during that time period. The manufacturer warranty for the Plastic Laminate Faced Casework shall commence after the equipment is delivered and demonstrated to Facilities, unless otherwise stipulated on a specific order issued by the District. (See #10 below for allowable exceptions.) *The District may make additional purchases at the itemized price listed in the bid packet for a period of one (1) year.*
7. The successful bidder shall make deliveries as stated on each order. All deliveries shall be made in accordance with good commercial practice and shall be adhered to by the successful bidder(s); except in such cases where the delivery will be delayed due to acts of God, strikes, or other causes beyond the control of the bidder. In these cases, the successful bidder shall notify the District of the delays in advance of the delivery dates so that a revised delivery schedule can be negotiated.

8. If the bidder experiences a back order of items from its manufacturer or distributor, the bidder shall ensure that such back orders are filled within twenty (20) calendar days from the date of the initial order. The successful bidder shall not invoice the District for back ordered items until such back orders are delivered and accepted by the District's authorized representative. It is understood and agreed that the District may, at its discretion, verbally cancel back orders after the grace period identified in this paragraph has lapsed, seek the items from another vendor and choose to cancel this contract.
9. Bidders are expected to bid on the equipment item as listed on the Equipment Specifications List. If there are any deviations from the specifications listed, the bidder is expected to make note on the bid form. The District reserves the right to determine the successful bidder and will make that decision based on the best interest of the District.
10. In the event a replacement product is necessary due to product failure, Facilities Department will work directly with the manufacturer under the applicable warranty coverage. A standard five (5) year warranty is preferred for this equipment purchase. If a five (5) year warranty is not offered, please provide information for an extended warranty option for purchase. (If applicable, may ask for one, two or ten-year warranty)
11. The successful bidder(s) must agree to accept the District's Purchase Order or the District's Visa P-card for the order. These purchases are tax exempt.
12. **Bids must be uploaded to Publicpurchase.com no later than 3:00 PM on Monday, July 2nd. Please note, registration with Public Purchase can take up to 36 hours, so do not wait until the day of the bid closing to register and upload your bid.**
13. The Lee's Summit R-VII School District will review all bid submissions with regards to pricing, product performance, and equipment features. The District plans to award the bid within 30 days after the bid opening.

GENERAL INVITATION TO BID INSTRUCTIONS

1. These General Terms, Conditions and Instructions apply to all proposals made to Lee's Summit R-VII School District (herein after referred to as "District") by each prospective vendor (herein after referred to as "Bidder") in response to District solicitations including, but not limited to, Invitations to Bids, Requests for Proposals and Requests for Quotes. As such, the words "Bid" and "Proposal" are used inter-changeably in reference to any and all offers submitted by prospective vendors.
2. **Public Purchase:** *It is the responsibility of the bidder to ensure that the bid is uploaded to the District's e-Procurement site, Public Purchase, prior to the time indicated in the "Invitation to Bid". Only questions posted through the e-Procurement site will be answered and posted for all interested bidders to see. Telephone quotes will not be accepted when competitive sealed bids are solicited. In addition, only bids upload to the District's Public Purchase site, will be accepted. Late bids will not be allowed by the Public Purchase site.*

3. Each Bidder shall furnish the information required; the unit price for each item and any variances in specifications must be shown.
4. Specifications are provided to identify the product required and to establish an acceptable quality level. Bids on products of equal quality and usability will normally be considered unless otherwise stated. Brochures and/or specifications must be submitted where applicable. Samples of item or items, when required, must be furnished free of expense to the District, and if not destroyed by tests, may upon request made at the time the sample is furnished, be returned at the Bidder's expense. Failure to furnish brochures, specifications, and/or samples as requested may be sufficient cause for rejection of Bids. Materials and/or services are to be supplied as specified. The District shall be the sole judge in determining "equals" in regard to quality, price, and performance.
5. The District reserves the right to reject any or all bids and to waive informalities and minor irregularities in bids received, and to accept any or all portions of a bid if deemed to be in the best interest of the District. The Invitation to Bid implies no obligation on the part of the District, and the District's silence does not imply any acceptance or rejection of any bid or quotation offer. The District reserves the right to select a bid with higher prices than the lowest of all prices received, if, in the opinion of the District, its interests will be best served by such bid.
6. Bidders are expected to examine the specifications, schedule of treatments of inspections and all instructions. Failure to do so will be at the bidder's risk.
7. Prices shall include all applicable discounts. If the successful bidder is offering a discount for quick payments, please state all payment terms in your bids.
8. The bid will be awarded to the responsive and responsible bidder(s) whose bid will be most advantageous to the District, price, specifications and other factors considered. The District reserves the right to waive any technical or formal error or omissions and reject any or all bids, or to award an agreement for the items thereon, either in part or in whole, if it is deemed to be in the best interest of the District to do so. Criteria that may be considered by the District in the award of this bid includes, but is not limited to, the following:
 - A. Superior quality and adherence to specifications
 - B. Delivery and/or completion time
 - C. Guarantees and warranties
 - D. Company's reputation and financial status
9. Any deviation from the specifications MUST be noted in detail, and submitted in writing with the bid packet. Complete specifications must be attached for any substitutions offered, or when amplifications are desirable or necessary. In the absence of a specification deviation statement and accompanying specifications, the bidder shall be held strictly accountable for full compliance with the specifications. Failure to submit a specification deviation

statement, if applicable, shall be grounds for rejection of the item when offered for delivery. If specifications or descriptive papers are submitted with bids, the bidder's name must be clearly shown on each document.

10. The Invitation to Bid does not obligate the District to pay any costs incurred in the preparation or the submission of such bids, or to purchase or contract for materials or services, including costs of any required bonding.
11. Bidders who are not selected must submit objection documents, exhibits or other evidence within five (5) business days of opening if they wish to protest any portion of the Invitation to Bid.
12. The Bid price shall be exclusive of any federal or state taxes, from which the District is exempt. The District's Federal Tax Identification Number is 44-6004933. The District's State of Missouri Tax Exemption Certificate number is 12585521. The District's State of Kansas Tax Exemption Certificate number is KSMMS4EKDC.
13. Bidder understands and agrees that the District may increase or decrease quantities or modify conditions and specifications by mutual agreement with the selected supplier.
14. The District shall not be responsible for any goods delivered or services performed without an approved purchase order, signed by an authorized representative of the District.
15. Other governmental agencies may be extended the opportunity to purchase off any Bid with the agreement of the successful vendor and the participating agencies. Due to all the variables in this type of bid, the District will contact the successful bidder and make it aware of the interest by another agency (if any). The successful bidder and the interested agency will then be able to design the successful bid around their parameters, i.e., delivery locations and specialty products.
16. **Provider must have the ability to accept the Lee's Summit R-VII School District Visa purchasing card.** The District has implemented a Visa Purchasing Card Program for ease of purchasing items, especially for smaller items. Use of the District Visa purchasing card is at the discretion of the ordering agency. If there are additional fees associated with accepting a District Visa purchasing card, this must be notated and explained on the bidder's response.
17. The bid process is open and fair to everyone. Every attempt shall be made to ensure that the bidder receives an adequate and prompt response. However, in order to maintain a fair and equitable procurement process, all bidders will be advised via the issuance of an amendment to the Invitation to Bid, of any relevant or pertinent information related to the procurement. Therefore, bidders are advised that unless specified elsewhere in the Invitation to Bid, any questions received less than five (5) calendar days prior to the opening date may not be answered.

Purchase Orders

1. **OFFER/ACCEPTANCE:** If the Purchase Order refers to Vendor's bid, then the Purchase Order is an ACCEPTANCE of Vendor's OFFER TO PROVIDE SERVICE, as stated in Vendor's bid. If no bid is referenced, the Purchase Order is an OFFER TO ORDER SERVICES, subject to Vendor's acceptance; which can be demonstrated by Vendor's performance of the order or by a formal acknowledgement. This section deals with items to purchase that may be provided by the successful bidder, but not listed on actual bid documents.
2. **CHANGES:** Any changes in prices to a Purchase Order shall be verified in writing, signed by an authorized representative of Lee's Summit R-VII School District and acknowledged by Vendor. Each service performed shall be deemed to be only upon the terms contained in the Purchase Order, notwithstanding any terms that may be contained in any invoice or other act of vendor other than acknowledgement of a written change submitted and approved by the District.
3. **DELIVERY:** In its acceptance of any quotation offer, Lee's Summit R-VII School District is relying on the promised delivery date, installation, and/or service performance as material and basic to its acceptance. In the event of Vendor's failure to deliver as and when promised, Lee's Summit R-VII School District reserves the right to cancel its order, or any part thereof, and vendor agrees that Lee's Summit R-VII School District may return all or part of any shipment so made, and may charge vendor with any loss or expense sustained as a result of such failure to deliver as promised.
4. **QUALITY:** Lee's Summit R-VII School District shall be the sole judge in determining "equals" in regard to quality, price and performance.
5. **INSPECTION:** Receipt of goods or services in response to the Purchase Order can result in authorized payment on the part of Lee's Summit R-VII School District. However, it is understood that final acceptance is dependent upon completion of all applicable required inspection procedures. Should the goods or services fail to meet all of Lee's Summit R-VII School District inspection requirements, Lee's Summit R-VII School District may exercise any or all of its rights allowed by law or in equity, including those provided in the Uniform Commercial Code. Vendor shall be responsible for inspection and replacement of all items damaged in shipment.
6. **WARRANTIES:** All goods covered by the Purchase Order are conveyed by vendor to Lee's Summit R-VII School District subject to the warranties and buyer's remedies described in the Uniform Commercial Code.
7. **TERMINATION:** In the event of the vendor's failure to deliver as and when specifically promised, Lee's Summit R-VII School District reserves the right to cancel the Purchase Order, or any part thereof, without prejudice to its other rights, and vendor agrees that Lee's Summit R-VII School District may return all or part of any shipment so made and may charge vendor any loss or expense sustained as a result of such failure to deliver as promised.

8. **DISCOUNT:** Any discount periods will start from the date of Lee's Summit R-VII School District receipt of an acceptable invoice or from the date of its receipt of acceptable service.
9. **TAXES:** Lee's Summit R-VII School District is exempt from Federal and State Taxes under the State of Missouri Tax Exemption Certificate #12585521 and under the State of Kansas Tax Exemption Certificate #KSMMS4EKDC.
10. **PRICES:** Vendor agrees, if its bid is accepted by Lee's Summit R-VII School District within the time specified, to furnish the goods and/or services in strict accordance with the specifications, and at the price set forth for each item. In case of error in extension, the unit price shall prevail. If the price is omitted on the Purchase Order, vendor's price shall be the lowest prevailing market price.
11. **PROMPT PAYMENT:** It is Lee's Summit R-VII District policy to promptly pay vendors for goods and services it purchases. Payments are processed net 30.
12. **ASSIGNMENT:** Except for assignment of antitrust claims, neither party to the agreement created by the Purchase Order may assign any portion of the agreement or Purchase Order without the prior written consent of the other party. Vendor, and Lee's Summit R-VII School District as purchaser, recognizes that in actual economic practice antitrust violations ultimately impact on the purchaser.
13. **O.S.H.A.:** All chemicals, equipment and materials proposed and/or used by vendor in satisfaction of the terms of the Purchase Order shall conform to the standards required by O.S.H.A.
14. **SAFETY DATA SHEETS (SDS)** shall accompany each shipment, when applicable.
15. **INDEMNIFICATION:** In the event any goods sold or services delivered under the Purchase Order are covered by any patent, copyright or trademark, or application therefore, vendor shall indemnify and hold harmless Lee's Summit R-VII School District from any and all loss, cost, expenses and legal fees on account of any claims, legal actions or judgments on account of manufacturer, sale or use of such goods in violation, infringement or the like or rights under such patent, copyright, trademark or application.
16. **GOVERNING LAW AND VENUE:** All issues regarding the formation, performance and/or legal enforcement of this Purchase Order shall be governed by and construed in accordance with the laws of the State of Missouri. Venue for the resolution of any disputes arising out of or relating to the Purchase Order shall be in Lee's Summit R-VII School District, Lee's Summit, Missouri.

Verification Affidavit for Selected Respondent to Complete:



Lee's Summit R-VII School District

301 NE Tudor Road
Lee's Summit, Missouri 64086
(816) 986-1000 • FAX (816) 986-1168

Business Services

As a condition for any service provided to the Lee's Summit R-VII School District, a business entity shall, by sworn affidavit and provision of documentation, affirm its enrollment and participation in a federal work authorization program with respect to the employees working in connection with the contracted services.

Every such business entity shall complete the following affidavit affirming that it does not knowingly employ any person who is an unauthorized alien in connection with the contract services. [RSMO 285.530 (2)]. The completed affidavit must be returned as part of the contract documentation or mailed to Lee's Summit R-VII School District, Attn: Accounts Payable, 301 NE Tudor Road, Lee's Summit, Missouri 64086.

This affidavit affirms that _____ (Company Name) is enrolled in, and is currently participating in, E-verify or any other equivalent electronic verification of work authorization operated by the United States Department of Homeland Security under the Immigration Reform and Control Act of 1986 (IRCA); and _____ (Company Name) does not knowingly employ any person who is unauthorized alien in conjunction with the contracted services.

Name (Please Print) of registered agent, legal representative or corporate officer

Title

Signature of registered agent, legal representative or corporate officer

Subscribed and sworn to before me this _____ of _____. I am commissioned as
(DAY) (MONTH, YEAR)

a notary public within the County of _____, State of _____, and my commission
(NAME OF COUNTY) (NAME OF STATE)

expires on _____.
(DATE)

Signature of Notary

Date

Failure to respond will cause payments due to you to be held until affidavit is received. Once the affidavit is received, payments will be released.

Bidder's Initials _____

Form W-9 (Rev. December 2011) Department of the Treasury Internal Revenue Service	Request for Taxpayer Identification Number and Certification	Give Form to the requester. Do not send to the IRS.
Print or type See Specific Instructions on page 2.	Name (as shown on your Income tax return)	
	Business name/disregarded entity name, if different from above	
	Check appropriate box for federal tax classification: <input type="checkbox"/> Individual/sole proprietor <input type="checkbox"/> C Corporation <input type="checkbox"/> S Corporation <input type="checkbox"/> Partnership <input type="checkbox"/> Trust/estate <input type="checkbox"/> Limited liability company. Enter the tax classification (C=C corporation, S=S corporation, P=partnership) ▶ _____ <input type="checkbox"/> Exempt payee <input type="checkbox"/> Other (see Instructions) ▶ _____	
	Address (number, street, and apt. or suite no.)	Requester's name and address (optional)
	City, state, and ZIP code	
	List account number(s) here (optional)	

Part I Taxpayer Identification Number (TIN)	Social security number								
Enter your TIN in the appropriate box. The TIN provided must match the name given on the "Name" line to avoid backup withholding. For individuals, this is your social security number (SSN). However, for a resident alien, sole proprietor, or disregarded entity, see the Part I instructions on page 3. For other entities, it is your employer identification number (EIN). If you do not have a number, see <i>How to get a TIN</i> on page 3.	<table border="1" style="width:100%; border-collapse: collapse;"> <tr> <td style="width:25%; height: 20px;"> </td> <td style="width:25%; height: 20px;"> </td> <td style="width:25%; height: 20px;"> </td> <td style="width:25%; height: 20px;"> </td> </tr> <tr> <td style="text-align: center;">-</td> <td style="text-align: center;">-</td> <td style="text-align: center;">-</td> <td style="text-align: center;">-</td> </tr> </table>					-	-	-	-
-	-	-	-						
Note. If the account is in more than one name, see the chart on page 4 for guidelines on whose number to enter.	Employer identification number <table border="1" style="width:100%; border-collapse: collapse;"> <tr> <td style="width:25%; height: 20px;"> </td> <td style="width:25%; height: 20px;"> </td> <td style="width:25%; height: 20px;"> </td> <td style="width:25%; height: 20px;"> </td> </tr> <tr> <td style="text-align: center;">-</td> <td style="text-align: center;">-</td> <td style="text-align: center;">-</td> <td style="text-align: center;">-</td> </tr> </table>					-	-	-	-
-	-	-	-						

Part II Certification	
Under penalties of perjury, I certify that:	
1. The number shown on this form is my correct taxpayer identification number (or I am waiting for a number to be issued to me), and 2. I am not subject to backup withholding because: (a) I am exempt from backup withholding, or (b) I have not been notified by the Internal Revenue Service (IRS) that I am subject to backup withholding as a result of a failure to report all interest or dividends, or (c) the IRS has notified me that I am no longer subject to backup withholding, and 3. I am a U.S. citizen or other U.S. person (defined below).	
Certification instructions. You must cross out item 2 above if you have been notified by the IRS that you are currently subject to backup withholding because you have failed to report all interest and dividends on your tax return. For real estate transactions, item 2 does not apply. For mortgage interest paid, acquisition or abandonment of secured property, cancellation of debt, contributions to an individual retirement arrangement (IRA), and generally, payments other than interest and dividends, you are not required to sign the certification, but you must provide your correct TIN. See the instructions on page 4.	
Sign Here Signature of U.S. person ▶ _____ Date ▶ _____	

General Instructions
 Section references are to the Internal Revenue Code unless otherwise noted.

Purpose of Form
 A person who is required to file an information return with the IRS must obtain your correct taxpayer identification number (TIN) to report, for example, income paid to you, real estate transactions, mortgage interest you paid, acquisition or abandonment of secured property, cancellation of debt, or contributions you made to an IRA.

Use Form W-9 only if you are a U.S. person (including a resident alien), to provide your correct TIN to the person requesting it (the requester) and, when applicable, to:

1. Certify that the TIN you are giving is correct (or you are waiting for a number to be issued),
2. Certify that you are not subject to backup withholding, or
3. Claim exemption from backup withholding if you are a U.S. exempt payee. If applicable, you are also certifying that as a U.S. person, your allocable share of any partnership income from a U.S. trade or business is not subject to the withholding tax on foreign partners' share of effectively connected income.

Note. If a requester gives you a form other than Form W-9 to request your TIN, you must use the requester's form if it is substantially similar to this Form W-9.

Definition of a U.S. person. For federal tax purposes, you are considered a U.S. person if you are:

- An individual who is a U.S. citizen or U.S. resident alien,
- A partnership, corporation, company, or association created or organized in the United States or under the laws of the United States,
- An estate (other than a foreign estate), or
- A domestic trust (as defined in Regulations section 301.7701-7).

Special rules for partnerships. Partnerships that conduct a trade or business in the United States are generally required to pay a withholding tax on any foreign partners' share of income from such business. Further, in certain cases where a Form W-9 has not been received, a partnership is required to presume that a partner is a foreign person, and pay the withholding tax. Therefore, if you are a U.S. person that is a partner in a partnership conducting a trade or business in the United States, provide Form W-9 to the partnership to establish your U.S. status and avoid withholding on your share of partnership income.

**Purchasing and Distribution Services
702 SE M291 Highway
Lee's Summit, Missouri 64063
(816) 986-2190**

**Pricing
Plastic Laminate Faced Casework**

Purchase of Plastic Laminate Faced Casework	Do the Specs meet Min. Spec Given?	If No, Give Explanation
Details	Yes/ No	Explanation of Difference
Cabinets		
Countertops		
Warranty (5 years preferred):		
Extended Warranty Cost (if applicable) \$ _____		
Manufacturer and catalog number:		
Price for Cabinets		\$
Price for Countertops		\$
Grand Total		\$

Vendor

Authorized Representative (Print)

Date

Authorized Signature

Telephone

Contact Email

Bidder's Initials _____

Exhibit A: Specifications and Drawings

SECTION 123216 - MANUFACTURED PLASTIC-LAMINATE-FACED CASEWORK

PART 1 - GENERAL

1.1 RELATED DOCUMENTS

- A. Drawings and general provisions of the Contract, including General and Supplementary Conditions and Division 01 Specification Sections, apply to this Section.

1.2 SUMMARY

- A. Section includes plastic-laminate-faced cabinets of stock design.
- B. Related Requirements:
 - 1. Section 123623.13 "Plastic-Laminate-Clad Countertops."
 - 2.

1.3 DEFINITIONS

- A. Definitions in the AWI's, AWMAC's, and WI's "Architectural Woodwork Standards" apply to the work of this Section.
- B. MDF: Medium-density fiberboard.
- C. Hardwood Plywood: A panel product composed of layers or plies of veneer, or of veneers in combination with lumber core, hardboard core, MDF core, or particleboard core, joined with adhesive, and faced both front and back with hardwood veneers.

1.4 COORDINATION

- A. Coordinate sizes and locations of framing, blocking, furring, reinforcements, and other related units of Work specified in other Sections to ensure that casework can be supported and installed as indicated.

1.5 ACTION SUBMITTALS

- A. Product Data: For each type of product.
- B. Shop Drawings: Include plans, elevations, sections, details, and attachments to other work. Show fabrication details, including types and locations of hardware. Show installation details, including field joints and filler panels. Indicate manufacturer's catalog numbers for casework.

1.6 INFORMATIONAL SUBMITTALS

- A. Quality Standard Compliance Certificates: AWI Quality Certification Program certificates.

1.7 QUALITY ASSURANCE

- A. Manufacturer Qualifications: A manufacturer that is certified for chain of custody by an FSC-accredited certification body.
- B. Installer Qualifications: a certified participant in AWI's Quality Certification Program.

1.8 DELIVERY, STORAGE, AND HANDLING

- A. Deliver casework only after painting, utility roughing-in, and similar operations that could damage, soil, or deteriorate casework have been completed in installation areas. If casework must be stored in other than installation areas, store only in areas where environmental conditions meet requirements specified in "Project Conditions" Article.
- B. Keep finished surfaces covered with polyethylene film or other protective covering during handling and installation.

1.9 FIELD CONDITIONS

- A. Environmental Limitations: Do not deliver or install casework until building is enclosed, wet work is complete, and HVAC system is operating and maintaining temperature and relative humidity at occupancy levels during the remainder of the construction period. Maintain temperature and relative humidity during the remainder of the construction period in range recommended for Project location by the AWI's, AWMAC's, and WI's "Architectural Woodwork Standards."
- B. Established Dimensions: Where casework is indicated to fit to other construction, establish dimensions for areas where woodwork is to fit. Provide allowance for trimming at site, and coordinate construction to ensure that actual dimensions correspond to established dimensions.
- C. Locate concealed framing, blocking, and reinforcements that support casework by field measurements before being enclosed, and indicate measurements on Shop Drawings.

1.10 WARRANTY

- A. Special Warranty: Manufacturer agrees to repair or replace components of casework that fail in materials or workmanship within specified warranty period.
 - 1. Failures include, but are not limited to, the following:
 - a. Delamination of components or other failures of glue bond.
 - b. Warping of components.
 - c. Failure of operating hardware.
 - 2. Warranty Period: Five years from date of Substantial Completion.

PART 2 - PRODUCTS

2.1 MANUFACTURERS

- A. Manufacturers/Contractors: Subject to compliance with requirements, provide products by one of the following:

1. Case Systems.
2. LSI Corporation of America; a Sagas International company.
3. Stevens Industries, Inc.
4. TMI Systems Design Corporation.
5. Precision Craft (Olathe, KS)
6. CS Humphrey & Company (Kansas City, MO)
7. Windham Millwork, Inc.
8. Timberline Millwork.

B. Source Limitations: Obtain plastic-laminate-faced cabinets from single manufacturer.

2.2 CASEWORK, GENERAL

A. Quality Standard: Unless otherwise indicated, comply with the AWI's, AWMAC's, and WI's "Architectural Woodwork Standards" for grades of casework indicated for construction, finishes, installation, and other requirements.

1. Grade: Custom.
2. Provide certificates from AWI certification program indicating that casework, including installation, complies with requirements of grades specified.

B. Product Designations: Drawings indicate sizes, configurations, and finish materials of manufactured plastic-laminate-faced cabinets by referencing designated manufacturer's catalog numbers. Other manufacturers' casework of similar sizes and door and drawer configurations, of same finish materials, and complying with the Specifications may be considered. See Section 016000 "Product Requirements."

C. Product Designations: Drawings indicate configurations of manufactured plastic-laminate-faced cabinets by referencing designations of Casework Design Series numbering system in Appendix A of the AWI's, AWMAC's, and WI's "Architectural Woodwork Standards."

2.3 CASEWORK

A. Design:

1. Flush overlay.

B. Grain Direction for Wood Grain Plastic Laminate:

1. Vertical on doors, horizontal on drawer fronts.

C. Exposed Materials:

1. Plastic Laminate: Grade HGS.
 - a. Colors and Patterns: As selected by owner from manufacturer's full range.
2. Unless otherwise indicated, provide specified edgebanding on all exposed edges.

D. Semiexposed Materials:

1. Thermoset Decorative Panels: Provide thermoset decorative panels for semiexposed surfaces unless otherwise indicated.

- a. Provide plastic laminate of same grade as exposed surfaces for interior faces of doors and drawer fronts and other locations where opposite side of component is exposed.
2. Unless otherwise indicated, provide specified edgebanding on all semiexposed edges.

- E. Concealed Materials:
1. Particleboard.

2.4 MATERIALS

- A. Maximum Moisture Content for Lumber: 7 percent for hardwood and 12 percent for softwood.
- B. Hardwood Plywood: HPVA HP-1, particleboard core except where veneer core is indicated
- C. Particleboard: ANSI A208.1, Grade M-2
- D. MDF: ANSI A208.2,
- E. Hardboard: ANSI A135.4, Class 1 Tempered.
- F. Plastic Laminate: High-pressure decorative laminate complying with NEMA LD 3.
 1. Manufacturers: Subject to compliance with requirements, provide products by one of the following:
 - a. Formica Corporation.
 - b. Panolam Industries International Inc.
 - c. Wilsonart International.
- G. Edgebanding for Plastic Laminate: Rigid PVC extrusions, through color with satin finish, 3 mm thick at doors and drawer fronts, 1 mm thick elsewhere.
- H. Thermoset Decorative Panels: Particleboard or medium-density fiberboard finished with thermally fused, melamine-impregnated decorative paper and complying with requirements of NEMA LD 3, Grade VGL, for Test Methods 3.3, 3.4, 3.6, 3.8, and 3.10.
- I. Edgebanding for Thermoset Decorative Panels: PVC or polyester edgebanding matching thermoset decorative panels.

2.5 COLORS AND FINISHES

- A. Thermoset Decorative Panel Colors, Patterns, and Finishes: As selected by Architect from casework manufacturer's full range.
- B. Plastic-Laminate Colors, Patterns, and Finishes: As selected by Architect from casework manufacturer's full range.
- C. PVC Edgebanding Color: As selected from casework manufacturer's full range.

2.6 FABRICATION

- A. Plastic-Laminate-Faced Cabinet Construction: As required by referenced quality standard, but not less than the following:

1. Bottoms and Ends of Cabinets, and Tops of Wall Cabinets and Tall Cabinets: 3/4-inch particleboard.
 2. Shelves: 3/4-inch- thick plywood or 1-inch- thick particleboard.
 3. Backs of Cabinets: 1/2-inch- thick particleboard or MDF where exposed, 1/4-inch hardboard dadoed into sides, bottoms, and tops where not exposed.
 4. Drawer Fronts: 3/4-inch particleboard.
 5. Drawer Sides and Backs: 1/2-inch solid-wood or veneer-core hardwood plywood, with glued dovetail or multiple-dowel joints.
 6. Drawer Bottoms: 1/4-inch hardwood plywood glued and dadoed into front, back, and sides of drawers. Use 1/2-inch material for drawers more than 24 inches wide.
 7. Doors 48 Inches High or Less: 3/4 inch thick, with particleboard or MDF cores.
 8. Doors More Than 48 Inches High: 1-1/8 inches thick, with particleboard cores.
- B. Filler Strips: Provide as needed to close spaces between cabinets and walls, ceilings, and indicated equipment. Fabricate from same material and with same finish as cabinets.

2.7 CASEWORK HARDWARE AND ACCESSORIES

- A. Hardware, General: Unless otherwise indicated, provide manufacturer's standard satin-finish, commercial-quality, heavy-duty hardware.
1. Use threaded metal or plastic inserts with machine screws for fastening to particleboard except where hardware is through-bolted from back side.
- B. Butt Hinges: Chrome-plated , semiconcealed, five-knuckle hinges complying with BHMA A156.9, Grade 1, with antifriction bearings and rounded tips. Provide two hinges for doors less than 48 inches high, and provide three hinges for doors more than 48 inches high.
- C. Pulls: Solid stainless-steel wire pulls, fastened from back with two screws. .
- D. Drawer Slides: BHMA A156.9, Type B05091.
1. Heavy Duty (Grade 1HD-100 and Grade 1HD-200): Side mounted; full-overtravel-extension type; zinc-plated, steel ball-bearing slides.
 2. Box Drawer Slides: Grade 1HD-100, for drawers not more than 6 inches high and 24 inches wide.
 3. File Drawer Slides: Grade 1HD-200, for drawers more than 6 inches high or 24 inches wide.
- E. Drawer and Hinged Door Locks: Cylindrical (cam) type, five-pin tumbler, brass with chrome-plated finish, and complying with BHMA A156.11, Grade 1.
1. Provide a minimum of two keys per lock and six master keys.
 2. Provide locks where indicated on drawings.
 3. Cabinets with pairs of doors shall have in-active left secured with "elbox catch" to permit active door to be secured to the in-active leaf.
- F. Adjustable Shelf Supports: Two-pin locking plastic shelf rests complying with BHMA A156.9, Type B04013.

PART 3 - EXECUTION

3.1 CASEWORK INSTALLATION

- A. All product will be installed by Owner.

END OF SECTION 123216

SECTION 123616 - METAL COUNTERTOPS

PART 1 - GENERAL

1.1 RELATED DOCUMENTS

- A. Drawings and general provisions of the Contract, including General and Supplementary Conditions and Division 01 Specification Sections, apply to this Section.

1.2 SUMMARY

- A. Section includes stainless-steel countertops.

1.3 ACTION SUBMITTALS

- A. Product Data: For each type of product.
- B. Shop Drawings: Include plans, sections, details, and attachments to other work. Detail fabrication and installation, including field joints.

1.4 DELIVERY, STORAGE, AND HANDLING

- A. Deliver metal countertops only after casework has been completed in installation areas.
- B. Keep finished surfaces covered with polyethylene film or other protective covering during handling and installation.

1.5 FIELD CONDITIONS

- A. Field Measurements: Verify actual dimensions of construction to receive metal countertops by field measurements before fabrication.

PART 2 - PRODUCTS

2.1 MATERIALS

- A. Stainless-Steel Sheet: ASTM A 240/A 240M, Type 304.
- B. Sealant for Countertops: Manufacturer's standard sealant of characteristics indicated below that complies with applicable requirements in Section 079200 "Joint Sealants."
 - 1. Mildew-Resistant Joint Sealant: Mildew resistant, single component, nonsag, neutral curing, silicone.
 - 2. Color: Clear.

2.2 STAINLESS-STEEL

- A. Countertops: Fabricate from 0.062-inch- thick, stainless-steel sheet. Provide smooth, clean exposed tops and edges in uniform plane, free of defects. Provide front and end overhang of 1 inch over the base cabinets.
 - 1. Joints: Fabricate countertops without field-made joints.
 - 2. Weld shop-made joints.
 - 3. Sound deaden the undersurface with heavy-build mastic coating.
 - 4. Extend the top down to provide a 1-inch- thick edge with a 1/2-inch return flange.
 - 5. Form the backsplash coved to and integral with top surface, with a 1/2-inch-thick top edge and 1/2-inch return flange.
 - 6. Provide raised (marine) edge around perimeter of tops containing sinks; pitch tops containing sinks two ways to provide drainage without channeling or grooving.

2.3 STAINLESS-STEEL FINISH

- A. Grind and polish surfaces to produce uniform, directional satin finish matching No. 4 finish, with no evidence of welds and free of cross scratches. Run grain with long dimension of each piece. When polishing is completed, passivate and rinse surfaces. Remove embedded foreign matter and leave surfaces clean.

PART 3 - EXECUTION

3.1 EXAMINATION

- A. Examine areas, with Installer present, for compliance with requirements for installation tolerances and other conditions affecting performance of metal countertops.
- B. Proceed with installation only after unsatisfactory conditions have been corrected.

3.2 INSTALLATION

- A. Install metal countertops level, plumb, and true; shim as required, using concealed shims.
- B. Field Jointing: Where possible, make field jointing in the same manner as shop jointing; use fasteners recommended by manufacturer. Prepare edges to be joined in shop so Project-site processing of top and edge surfaces is not required. Locate field joints where shown on Shop Drawings.
- C. Secure tops to cabinets with Z- or L-type fasteners or equivalent; use two or more fasteners at each front, end, and back.
- D. Abut top and edge surfaces in one true plane, with internal supports placed to prevent deflection.
- E. Seal junctures of tops, splashes, and walls with mildew-resistant silicone sealant or another permanently elastic sealing compound recommended by countertop material manufacturer.

3.3 CLEANING AND PROTECTION

- A. Repair or remove and replace defective work as directed on completion of installation.

- B. Clean finished surfaces, touch up as required, and remove or refinish damaged or soiled areas to match original factory finish, as approved by Architect.
- C. Protection: Provide 6-mil plastic or other suitable water-resistant covering over the countertop surfaces. Tape to underside of countertop at a minimum of 48 inches o.c. Remove protection at Substantial Completion.

END OF SECTION 123616

SECTION 123623.13 - PLASTIC-LAMINATE-CLAD COUNTERTOPS

PART 1 - GENERAL

1.1 RELATED DOCUMENTS

- A. Drawings and general provisions of the Contract, including General and Supplementary Conditions and Division 01 Specification Sections, apply to this Section.

1.2 SUMMARY

- A. Section includes plastic-laminate countertops.

1.3 ACTION SUBMITTALS

- A. Product Data: For each type of product.
- B. Shop Drawings: Show location of each item, dimensioned plans and elevations, large-scale details, attachment devices, and other components.
 - 1. Show locations and sizes of cutouts and holes for plumbing fixtures faucets electrical switches and outlets and other items installed in plastic-laminate countertops.
 - 2. Apply AWI Quality Certification Program label to ShopDrawings.

1.4 INFORMATIONAL SUBMITTALS

- A. Woodwork Quality Standard Compliance Certificates: AWI Quality Certification Programcertificates.

1.5 QUALITY ASSURANCE

- A. Fabricator Qualifications: Shop that employs skilled workers who custom fabricate products similar to those required for this Project and whose products have a record of successful in-service performance. Shop is a certified participant in AWI's Quality Certification Program.
- B. Installer Qualifications: Certified participant in AWI's Quality Certification Program.
- C. Testing Agency Qualifications: For testing agency providing classification marking for fire-retardant-treated material, an inspection agency acceptable to authorities having jurisdiction that periodically performs inspections to verify that the material bearing the classification marking is representative of the material tested.

1.6 DELIVERY, STORAGE, AND HANDLING

- A. Do not deliver countertops until painting and similar operations that could damage countertops have been completed in installation areas. If countertops must be stored in other than installation areas, store only in areas where environmental conditions comply with requirements specified in "Field Conditions" Article.

1.7 FIELD CONDITIONS

- A. Environmental Limitations: Do not deliver or install countertops until building is enclosed, wet work is complete, and HVAC system is operating and maintaining temperature and relative humidity at occupancy levels during the remainder of the construction period.
- B. Environmental Limitations: Do not deliver or install countertops until building is enclosed, wet work is complete, and HVAC system is operating and maintaining temperature between 60 and 90 deg F and relative humidity between 43 and 70 percent during the remainder of the construction period.
- C. Field Measurements: Where countertops are indicated to fit to other construction, verify dimensions of other construction by field measurements before fabrication, and indicate measurements on Shop Drawings. Coordinate fabrication schedule with construction progress to avoid delaying the Work.
- D. Established Dimensions: Where countertops are indicated to fit to other construction, establish dimensions for areas where countertops are to fit. Provide allowance for trimming at site, and coordinate construction to ensure that actual dimensions correspond to established dimensions.

PART 2 - PRODUCTS

2.1 PLASTIC-LAMINATE COUNTERTOPS

- A. Quality Standard: Unless otherwise indicated, comply with the "Architectural Woodwork Standards" for grades indicated for construction, installation, and other requirements.
 - 1. Provide labels and certificates from AWI certification program indicating that countertops, including installation, comply with requirements of grades specified.
 - 2. The Contract Documents contain selections chosen from options in the quality standard and additional requirements beyond those of the quality standard. Comply with those selections and requirements in addition to the quality standard.
- B. Grade: Premium.
- C. High-Pressure Decorative Laminate: NEMA LD 3, Grade HGS.
 - 1. Manufacturers: Subject to compliance with requirements, provide products by one of the following:
 - a. Formica Corporation.
 - b. Panolam Industries International, Inc.
 - c. Wilsonart International Holdings, Inc.
- D. Colors, Patterns, and Finishes: Provide materials and products that result in colors and textures of exposed laminate surfaces complying with the following requirements:
 - 1. As selected by architect from manufacturer's full range.
 - 2. Grain Direction: Parallel to cabinet fronts.
- E. Edge Treatment: 3-mm PVC edging .
- F. Core Material: Particleboard made with exterior glue .
- G. Core Material at Sinks: or exterior-grade plywood.

- H. Core Thickness: 1-1/8 inch.
 - 1. Build up countertop thickness to 1-1/2 inches at front, back, and ends with additional layers of core material laminated to top.
- I. Backer Sheet: Provide plastic-laminate backer sheet, NEMA LD 3, Grade BKL, on underside of countertop substrate.

2.2 WOOD MATERIALS

- A. Wood Products: Provide materials that comply with requirements of referenced quality standard unless otherwise indicated.
 - 1. Wood Moisture Content: 5 to 10 percent.

2.3 ACCESSORIES

- A. Grommets for Cable Passage through Countertops: 2-inch OD, black, molded-plastic grommets and matching plastic caps with slot for wire passage.
 - 1. Products: Subject to compliance with requirements, provide one of the following:
 - a. Doug Mockett & Company, Inc.; TG3 2" Flip-Top Grommet Set .

2.4 MISCELLANEOUS MATERIALS

- A. Adhesives: Do not use adhesives that contain urea formaldehyde.
- B. Adhesive for Bonding Plastic Laminate: Contact cement .
 - 1. Adhesive for Bonding Edges: Hot-melt adhesive.
- C. VOC Limits for Installation Adhesives and Sealants: Use products that comply with the following limits for VOC content when calculated according to 40 CFR 59, Subpart D (EPA Method 24):
 - 1. Wood Glues: 30 g/L.
 - 2. Multipurpose Construction Adhesives: 70 g/L.
 - 3. Structural Wood Member Adhesive: 140 g/L.
 - 4. Architectural Sealants: 250 g/L.

2.5 FABRICATION

- A. Fabricate countertops to dimensions, profiles, and details indicated. Provide front and end overhang of 1 inch over base cabinets. Ease edges to radius indicated for the following:
 - 1. Solid-Wood (Lumber) Members: 1/16 inch unless otherwise indicated.
- B. Complete fabrication, including assembly, to maximum extent possible before shipment to Project site. Disassemble components only as necessary for shipment and installation. Where necessary for fitting at site, provide ample allowance for scribing, trimming, and fitting.

1. Notify Architect seven days in advance of the dates and times woodwork fabrication will be complete.
 2. Trial fit assemblies at fabrication shop that cannot be shipped completely assembled. Install dowels, screws, bolted connectors, and other fastening devices that can be removed after trial fitting. Verify that various parts fit as intended and check measurements of assemblies against field measurements before disassembling for shipment.
- C. Shop cut openings to maximum extent possible to receive appliances, plumbing fixtures, electrical work, and similar items. Locate openings accurately and use templates or roughing-in diagrams to produce accurately sized and shaped openings. Sand edges of cutouts to remove splinters and burrs.
1. Seal edges of openings in countertops with a coat of varnish.

PART 3 - EXECUTION

3.1 PREPARATION

- A. Before installation, condition countertops to average prevailing humidity conditions in installation areas.
- B. Before installing countertops, examine shop-fabricated work for completion and complete work as required, including removal of packing and backpriming.

3.2 INSTALLATION

- A. Grade: Install countertops to comply with same grade as item to be installed.
- B. Assemble countertops and complete fabrication at Project site to the extent that it was not completed in the shop.
 1. Provide cutouts for appliances, plumbing fixtures, electrical work, and similar items.
 2. Seal edges of cutouts by saturating with varnish.
- C. Field Jointing: Where possible, make in the same manner as shop jointing, using dowels, splines, adhesives, and fasteners recommended by manufacturer. Prepare edges to be joined in shop so Project-site processing of top and edge surfaces is not required. Locate field joints where shown on Shop Drawings.
 1. Secure field joints in plastic-laminate countertops with concealed clamping devices located within 6 inches of front and back edges and at intervals not exceeding 24 inches. Tighten according to manufacturer's written instructions to exert a constant, heavy-clamping pressure at joints.
- D. Install countertops level, plumb, true, and straight. Shim as required with concealed shims. Install level and plumb to a tolerance of 1/8 inch in 96 inches.
- E. Scribe and cut countertops to fit adjoining work, refinish cut surfaces, and repair damaged finish at cuts.
- F. Countertops: Anchor securely by screwing through corner blocks of base cabinets or other supports into underside of countertop.
 1. Install countertops with no more than 1/8 inch in 96-inch sag, bow, or other variation from a straight line.
 2. Secure backsplashes to tops with concealed metal brackets at 16 inches o.c. and to walls with adhesive.

3. Seal junctures of tops, splashes, and walls with mildew-resistant silicone sealant or another permanently elastic sealing compound recommended by countertop material manufacturer.

3.3 ADJUSTING AND CLEANING

- A. Repair damaged and defective countertops, where possible, to eliminate functional and visual defects; where not possible to repair, replace woodwork. Adjust joinery for uniform appearance.
- B. Clean countertops on exposed and semiexposed surfaces. Touch up shop-applied finishes to restore damaged or soiled areas.

END OF SECTION 123623.13

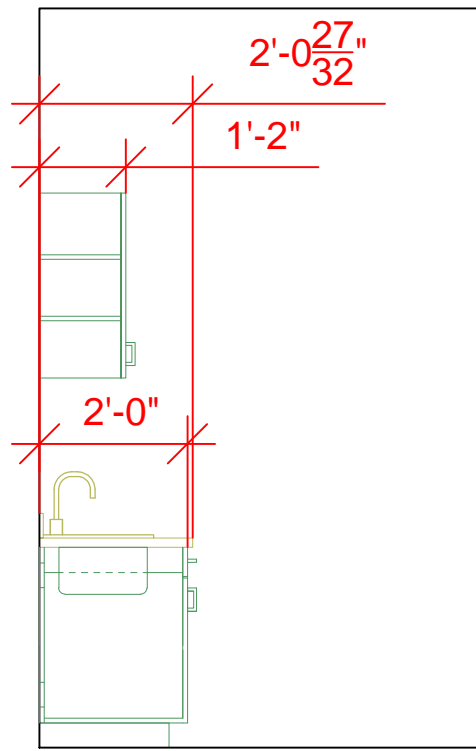

7 ART - NORTH SECTION
.375" = 1'-0"

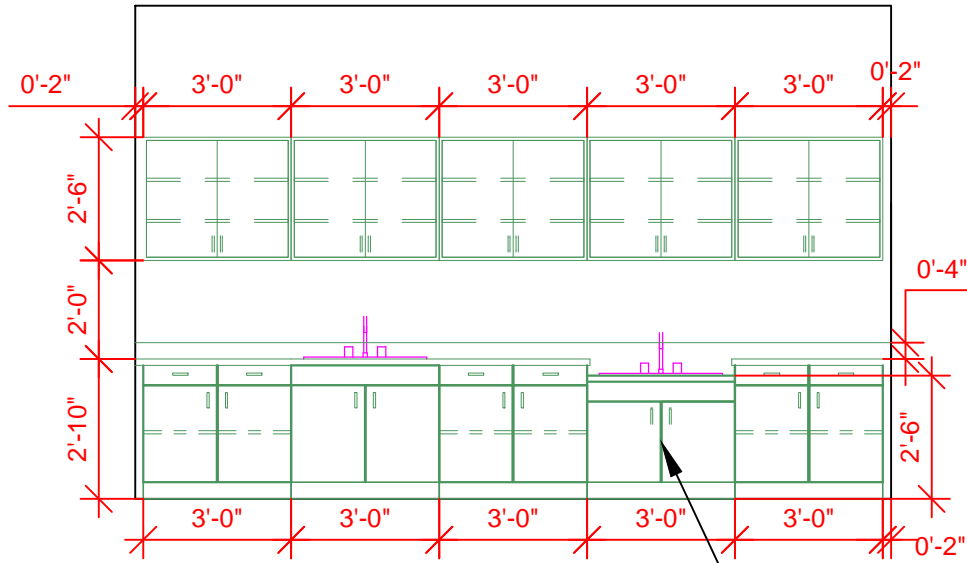

6 ART - NORTH WALL
1/4" = 1'-0"

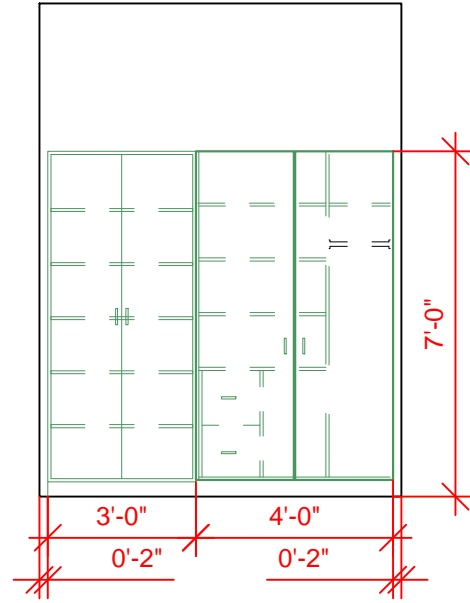

5 ART - NORTH WALL
1/4" = 1'-0"

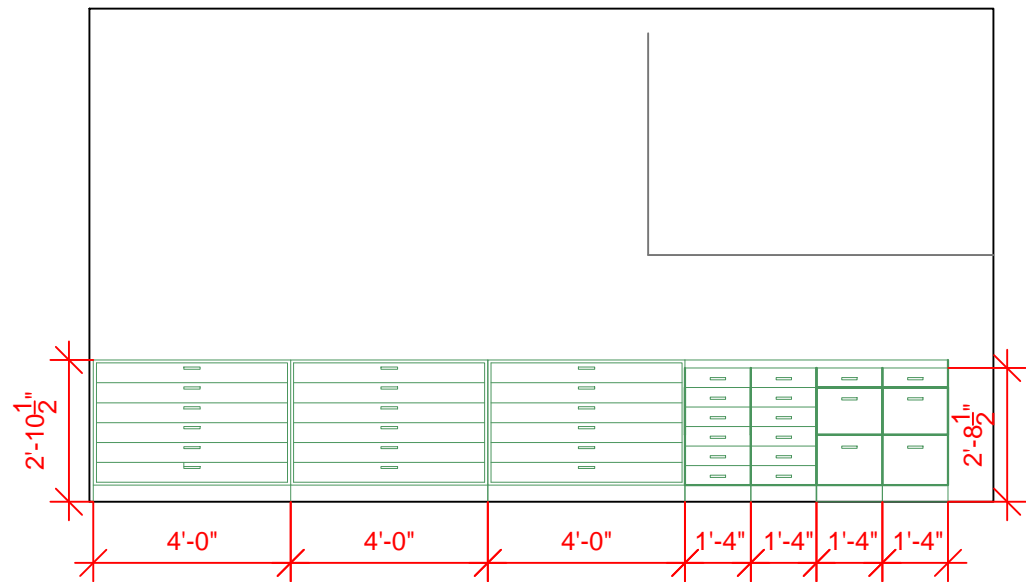

4 ART - WEST WALL
1/4" = 1'-0"

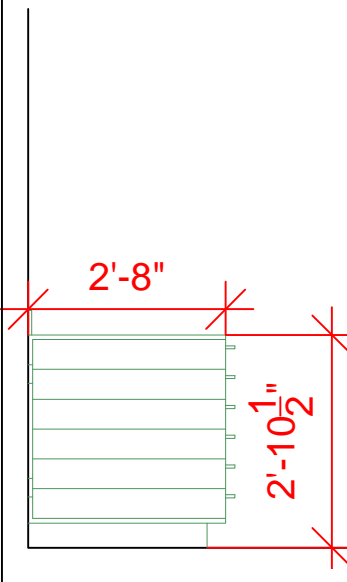

3 ART - WEST SECTION
.375" = 1'-0"

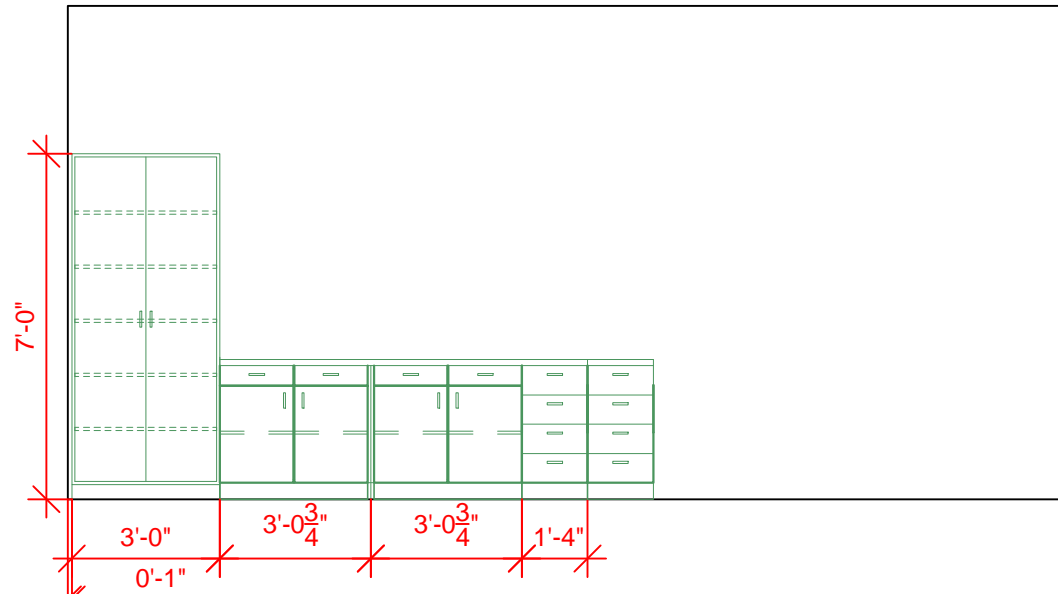

2 ART - EAST WALL
1/4" = 1'-0"

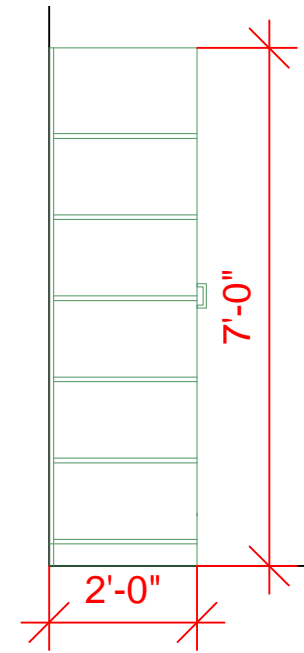

1 ART - EAST SECTION
.375" = 1'-0"





LEE'S SUMMIT
R-7 SCHOOLS
Learning for Life

Facilities Services
Lee's Summit, MO
Revision Date: 05.31.2018
File Name: PLEArtRoom.DWG

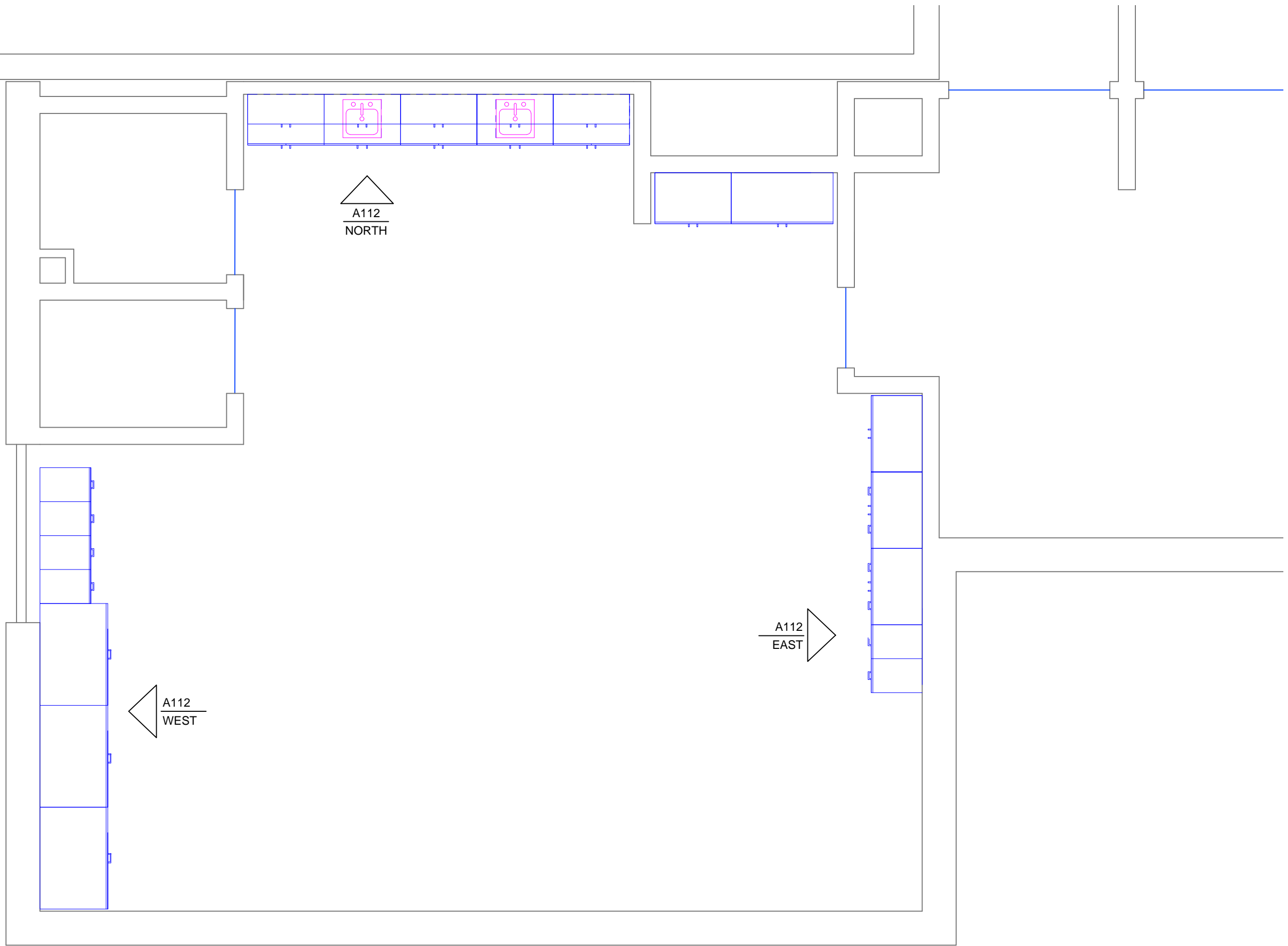

PLE Art Room

ART PLAN

A11.1

Scale: 1/4"=1'-00"

